

**Y12 Transition Work:  
Exam Practice**

Name: \_\_\_\_\_

Class: \_\_\_\_\_

Date: \_\_\_\_\_

---

Time: **129 minutes**

Marks: **123 marks**

Comments:

---

**Q1.** Figure 1 shows a student walking on a carpet.

**Figure 1**



- (a) The student becomes negatively charged because of the friction between her socks and the carpet.

Explain why the friction causes the student to become charged.

---

---

---

---

(2)

- (b) The student's head is represented by the sphere in **Figure 2**.

The student is negatively charged. The arrow shows part of the electric field around the student's head.

Draw **three** more arrows on **Figure 2** to complete the electric field pattern.

**Figure 2**

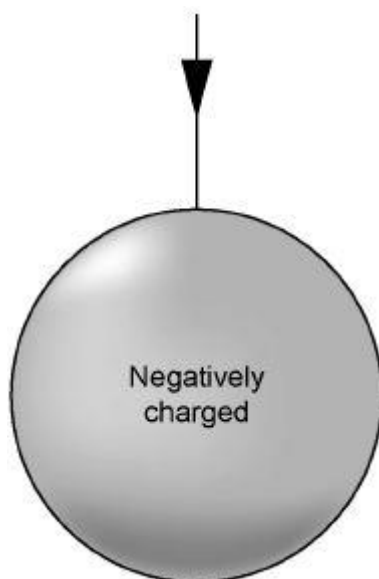

(1)

- (c) The negatively charged student touches a metal tap and receives an electric shock.

Explain why.

---

---

---

---

---

---

---

**(3)**

- (d) Some carpets have thin copper wires running through them. The student is less likely to receive an electric shock after walking on this type of carpet.

Suggest why.

---

---

---

---

---

---

---

**(2)**

**(Total 8 marks)**

**Q2.** The photograph below shows a balloon filled with helium gas.



(a) Which statements describe the movement of the gas particles in the balloon?

Tick (✓) **two** boxes.

The particles all move in a predictable way.

The particles move at the same speed.

The particles move in circular paths.

The particles move in random directions.

The particles move with a range of speeds.

The particles vibrate about fixed positions.

(2)

(b) The pressure of the helium in the balloon is 100 000 Pa.

The volume of the balloon is 0.030 m<sup>3</sup>.

The balloon is compressed at a constant temperature causing the volume to decrease to 0.025 m<sup>3</sup>.

No helium leaves the balloon. Calculate the new pressure in the balloon.

---

---

---

---

---

New pressure = \_\_\_\_\_ Pa

(c) The temperature of the helium in the balloon was increased.

The mass and volume of helium in the balloon remained constant.

Explain why the pressure exerted by the helium inside the balloon would increase.

---

---

---

---

---

---

---

---

---

---

(4)

(Total 10 marks)

**Q3.**

Smoke alarms contain an alpha radiation source and a radiation detector.

**Figure 1** shows part of the inside of a smoke alarm.

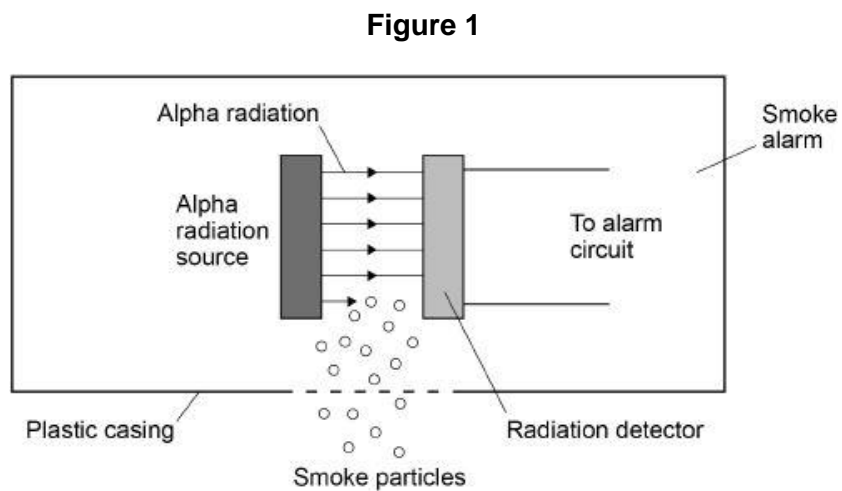

(a) The smoke alarm stays off while alpha radiation reaches the detector.

Why does the alarm switch on when smoke particles enter the plastic casing?

---

---

---

(1)

(b) Why is it safe to use a source of alpha radiation in a house?

---

---

---

(1)

(c) The smoke alarm would not work with a radiation source that emits beta or gamma radiation.

Explain why.

---

---

---

---

(2)

(d) **Figure 2** shows how the count rate detected from the radiation source in the smoke alarm changes with time.

**Figure 2**

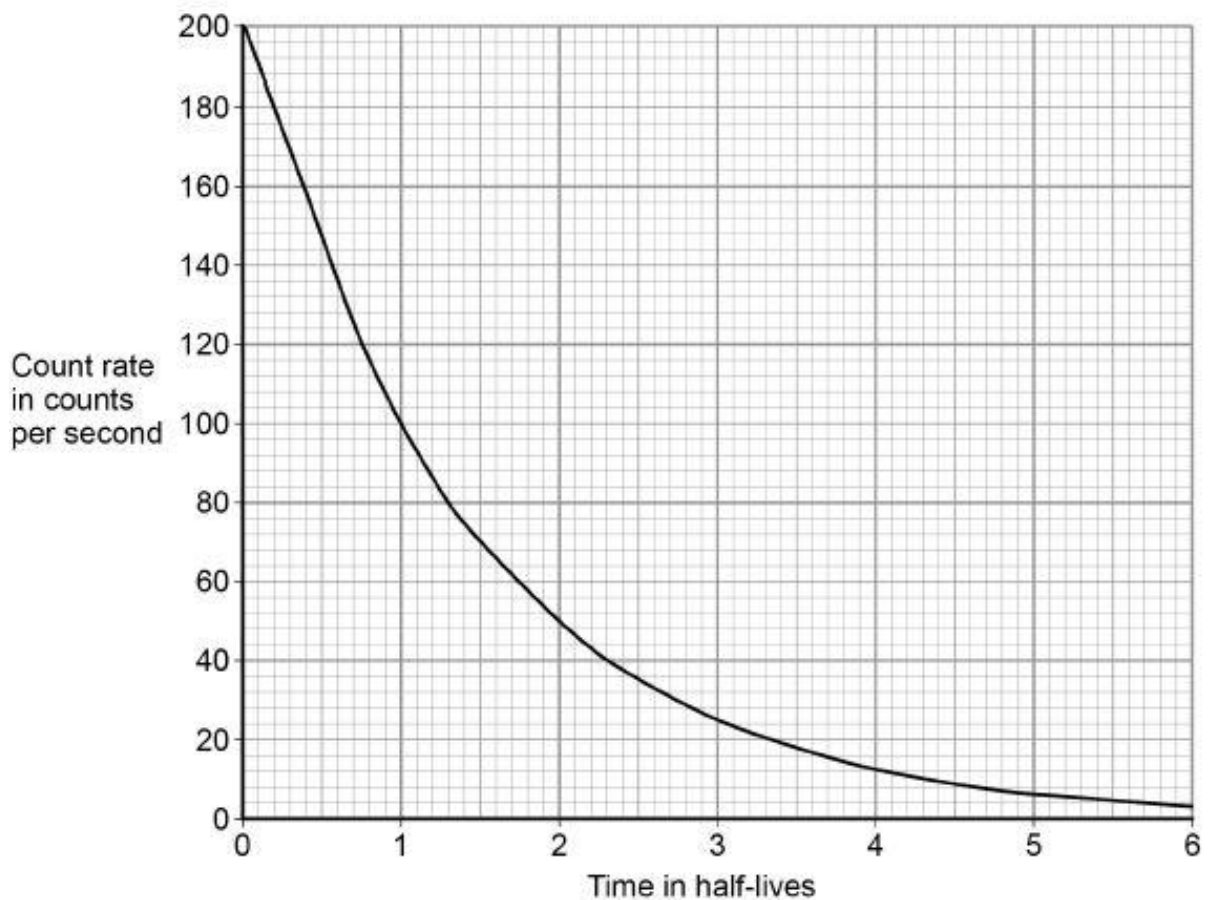

The smoke alarm switches on when the count rate falls to 80 counts per second.

Explain why the radiation source inside the smoke alarm should have a long half-life.

---

---

---

---

(2)

- (e) **Figure 3** shows a patient who has been injected with a radioactive source for medical diagnosis.

**Figure 3**



Explain the ideal properties of a radioactive source for use in medical diagnosis.

---

---

---

---

---

---

---

---

(4)

(Total 10 marks)

**Q4.**

Radioactive waste from nuclear power stations is a man-made source of background radiation.

- (a) Give **one** other man-made source of background radiation.

---

(1)

Nuclear power stations use the energy released by nuclear fission to generate electricity.

- (b) Give the name of **one** nuclear fuel.

---

(1)

- (c) Nuclear fission releases energy.

Describe the process of nuclear fission inside a nuclear reactor.

---

---

---

---

---

---

---

---

---

---

(4)

- (d) A new type of power station is being developed that will generate electricity using nuclear fusion.

Explain how the process of nuclear fusion leads to the release of energy.

---

---

---

---

(2)



- (e) Nuclear fusion power stations will produce radioactive waste. This waste will have a much shorter half-life than the radioactive waste from a nuclear fission power station.

Explain the advantage of the radioactive waste having a shorter half-life.

---

---

---

---

(2)  
(Total 10 marks)

**Q5.**

The diagram shows a man standing in an airport queue with his wheeled bag.

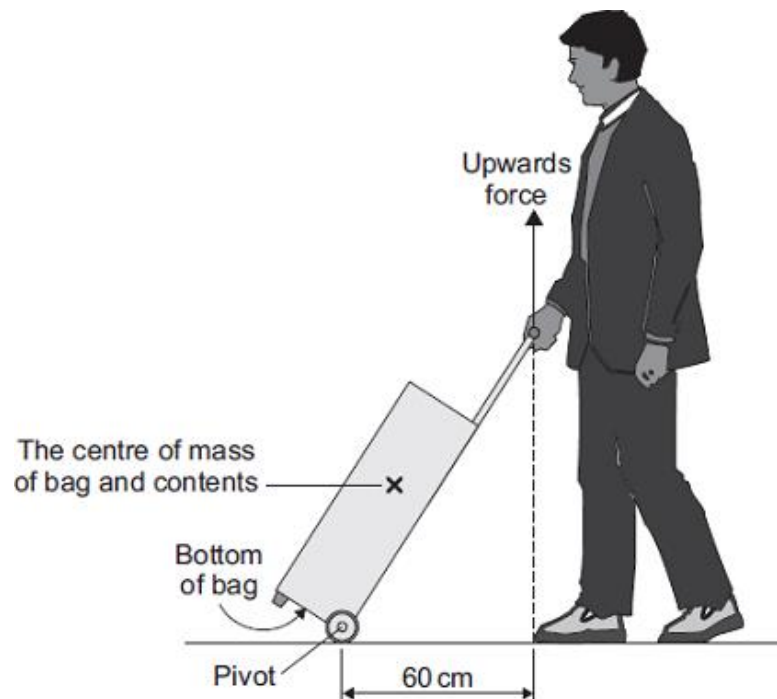

- (a) The man applies an upward force to the handle of his bag to stop the bag from falling.  
The moment of this force about the pivot is 36 Nm.

Calculate the upward force the man applies to the handle of his bag.

---

---

---

---

Force = \_\_\_\_\_ N

(2)

(b) When the man lets go of the bag handle, the bag falls and hits the floor.

Explain why.

---

---

---

---

---

---

---

(2)

(Total 4 marks)

**Q6.**

Diving bricks sink to the bottom of a swimming pool.

**Figure 1** shows a diving brick.

**Figure 1**

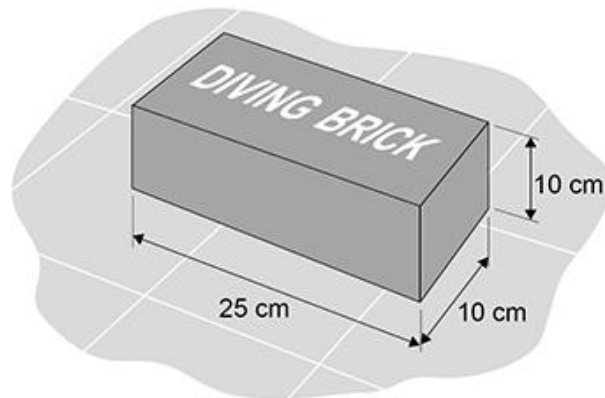

Swimmers practise diving to the bottom of the swimming pool to pick up the diving brick.

(a) Explain why the forces on the brick at the bottom of the pool cause the brick to be stationary.

---

---

---

---

---

---

---

(3)



(c) Professional divers are trained in a very deep swimming pool.

The density of the water in this pool is **not** the same as the density of the water in part (b).

The diving brick was dropped into the very deep swimming pool.

When the brick was at a depth of 2.50 m, the force due to the weight of the water on the top surface of the brick was 618 N.

**Figure 2** shows the diving brick at the bottom of the very deep swimming pool.

**Figure 2**

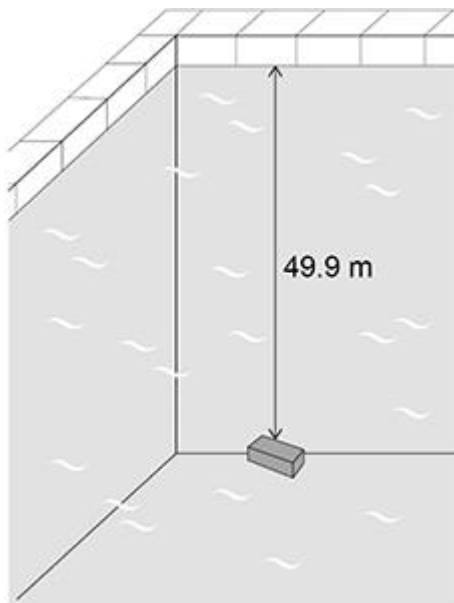

Determine the force due to the weight of the water on the top surface of the brick in **Figure 2**.

Use the Physics Equations Sheet.

Give your answer to 3 significant figures.

---

---

---

---

---

Force (3 significant figures) = \_\_\_\_\_ N

(3)

(Total 12 marks)

**Q7.**

The image below shows two ice hockey players moving towards each other.

They collide and then move off together.

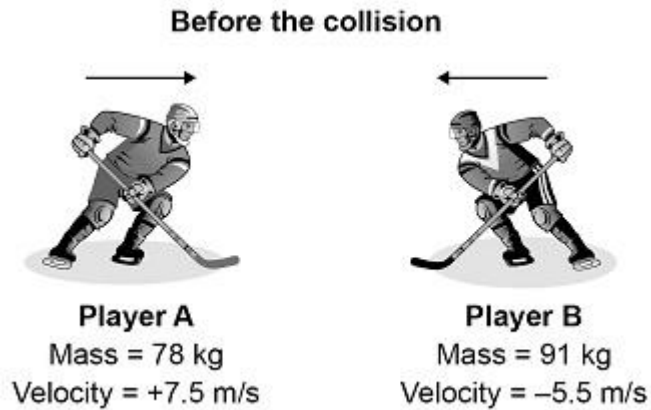

During the collision, the total momentum of the players is conserved.

(a) What is meant by 'momentum is conserved'?

---

---

(1)

(b) Immediately after the collision the two players move together to the right.

Calculate the velocity of the two players immediately after the collision.

---

---

---

---

---

---

---

---

---

---

Velocity = \_\_\_\_\_ m/s

(4)

- (c) The ice hockey players wear protective pads filled with foam.

Explain how the protective pads help to reduce injury when the players collide.

---

---

---

---

---

---

---

(3)

(Total 8 marks)

**Q8.**

The picture shows a pre-natal scan obtained using ultrasonic waves.



- (i) Explain how ultrasonic waves are used to produce the image of an unborn baby.

---

---

---

---

---

(2)

- (ii) Give another use for ultrasonic waves.

---

(1)

(Total 3 marks)

**Q9.**

- (a) **Figure 1** shows parallel rays of light being refracted by a convex lens.

**Figure 1**

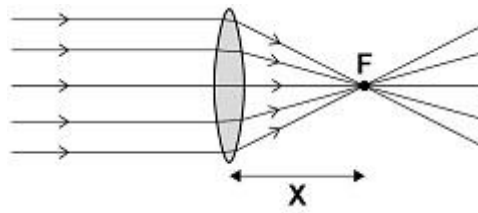

What is distance 'X' called?

---

(1)

- (b) Lenses can be used to form the image of an object.

Complete the ray diagram in **Figure 2** to show how a **convex** lens forms the image of the object.

Use an arrow to represent the image.

**Figure 2**

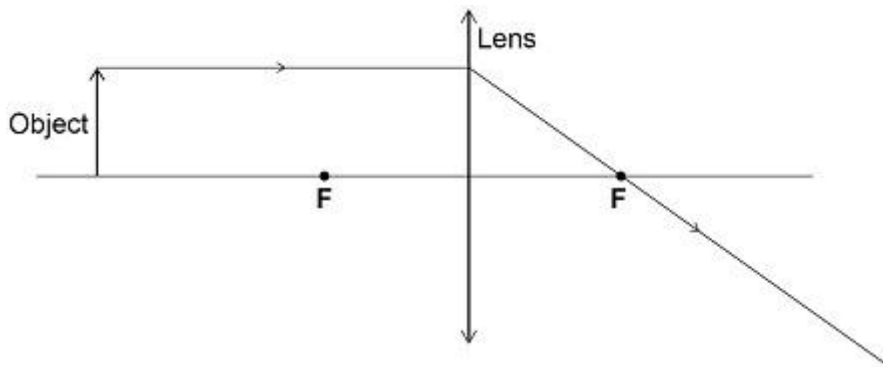

(2)

**Figure 3** shows how a concave lens forms the image of an object.

**Figure 3**

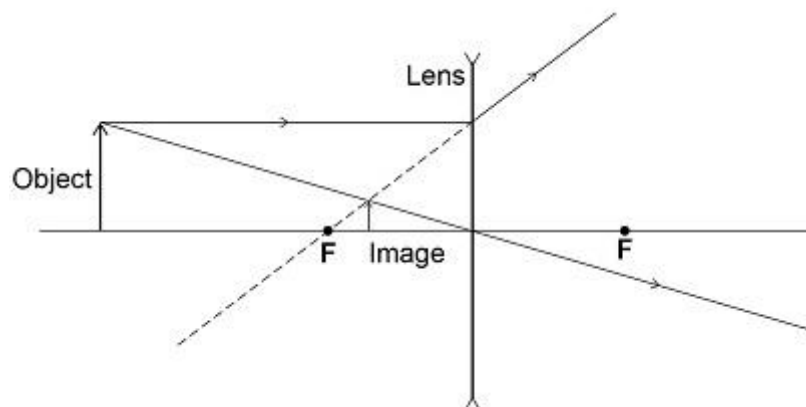

- (c) Give **one** similarity and **one** difference between the image formed by the convex lens and the image formed by the concave lens.

Similarity \_\_\_\_\_

\_\_\_\_\_

Difference \_\_\_\_\_

\_\_\_\_\_

(2)

- (d) A person uses a lens to read the letters on the back of a coin.

The image height of the letters on the coin is 9.0 mm

The magnification produced by the lens is 6.0

Calculate the height of the letters on the coin.

Use the Physics Equations sheet.

\_\_\_\_\_

\_\_\_\_\_

\_\_\_\_\_

\_\_\_\_\_

Height = \_\_\_\_\_ mm

(3)

(Total 8 marks)

**Q10.**

**Figure 1** shows what happens when a ray of light enters a tin can through a small hole.

**Figure 1**

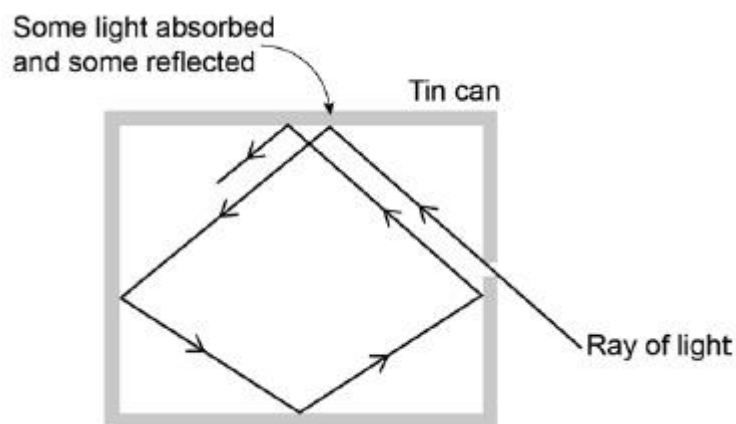



(a) Explain why the small hole looks black.

---

---

---

---

---

(2)

(b) All objects absorb and emit radiation.

What is meant when an object is described as a perfect black body?

---

---

(1)

**Figure 2** shows how the intensity of different wavelengths of radiation from a hot object varies with temperature.

**Figure 2**

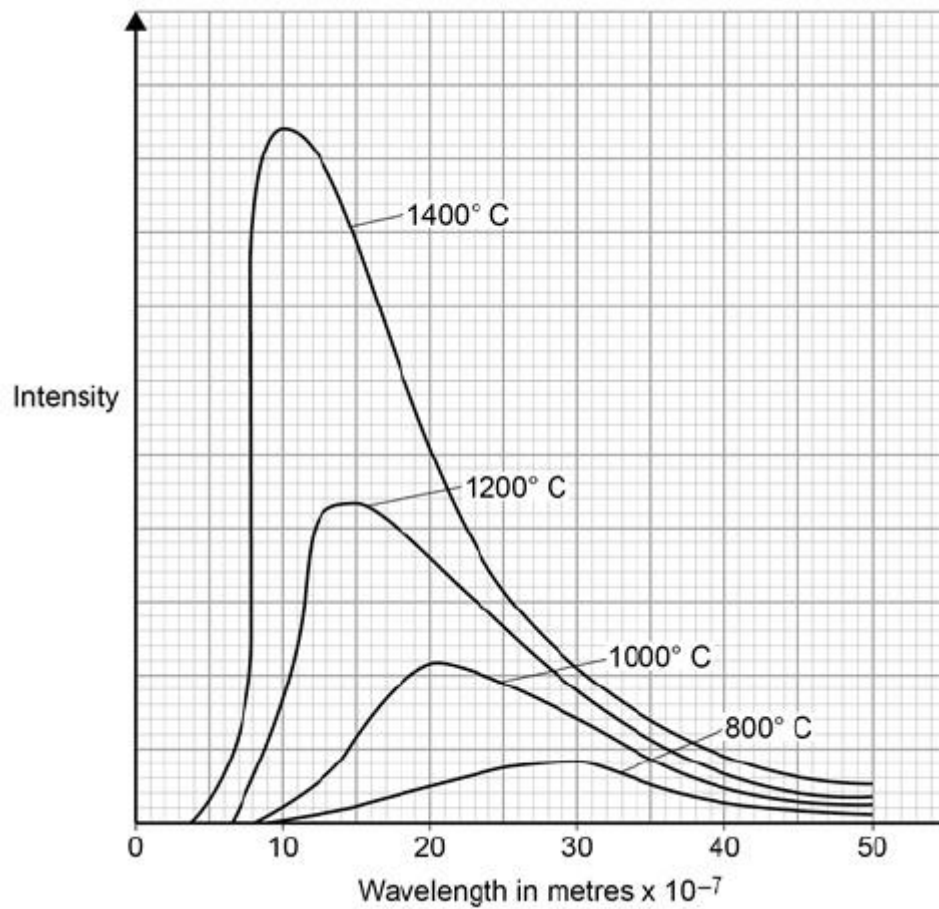

- (c) What can be concluded from **Figure 2** about how the distribution of the intensity of radiation from an object changes as the temperature of the object increases?

---



---



---



---

(3)

- (d) The wavelength at which the Sun emits the maximum intensity of radiation is approximately  $5 \times 10^{-7}$  m. Estimate the surface temperature of the Sun.

Use **Figure 2**.

---

(1)

- (e) **Figure 3** shows how the balance between the incident radiation from space and the radiation emitted by the Earth into space has changed over the last 200 years.

**Figure 3**

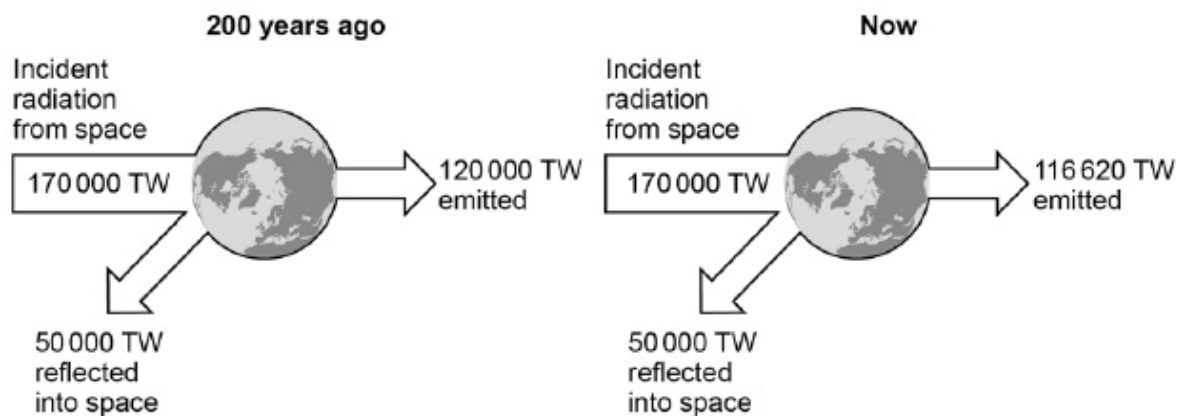

Explain how the temperature of the Earth and its atmosphere has changed over the last 200 years. Use the information in **Figure 3**.

---



---



---



---



---



---



---

(3)

(Total 10 marks)

**Q11.**

The diagram shows an a.c. generator.

The coil rotates about the axis shown and cuts through the magnetic field produced by the magnets.

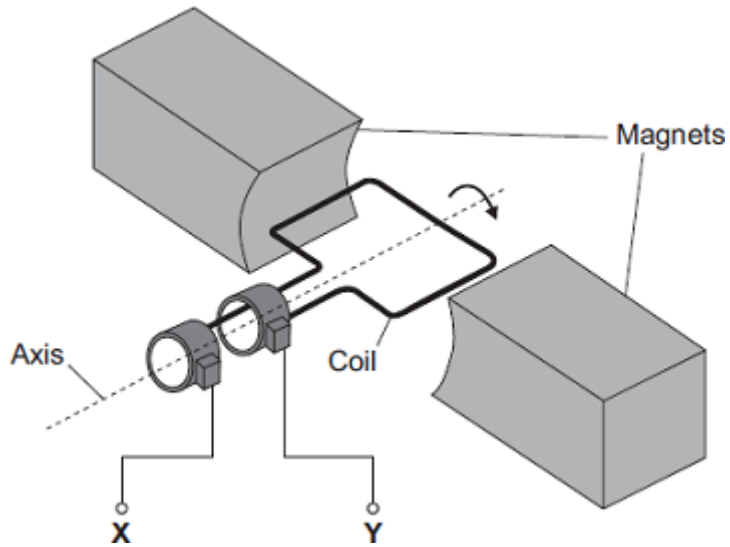

- (a) (i) A potential difference is induced between **X** and **Y**.

Use the correct answer from the box to complete the sentence.

electric	generator	motor	transformer
----------	-----------	-------	-------------

This effect is called the \_\_\_\_\_ effect.

(1)

- (ii) What do the letters a.c. stand for?

\_\_\_\_\_

(1)

- (iii) Name an instrument that could be used to measure the potential difference between **X** and **Y**.

\_\_\_\_\_

(1)

- (b) **Graph 1** shows the output from the a.c. generator.

**Graph 1**

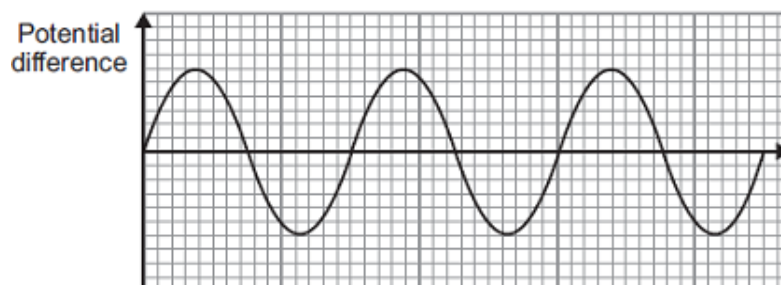

- (i) One of the axes on **Graph 1** has been labelled 'Potential difference'.

What should the other axis be labelled?

\_\_\_\_\_

(1)

- (ii) The direction of the magnetic field is reversed.

On **Graph 1**, draw the output from the a.c. generator if everything else remains the same.

(2)

- (c) The number of turns of wire on the coil is increased. This increases the maximum induced potential difference.

State **two** other ways in which the maximum induced potential difference could be increased.

1. \_\_\_\_\_

\_\_\_\_\_

2. \_\_\_\_\_

\_\_\_\_\_

(2)

(Total 8 marks)

### Q12.

A student made a moving-coil loudspeaker.

The figure below shows a diagram of the loudspeaker.

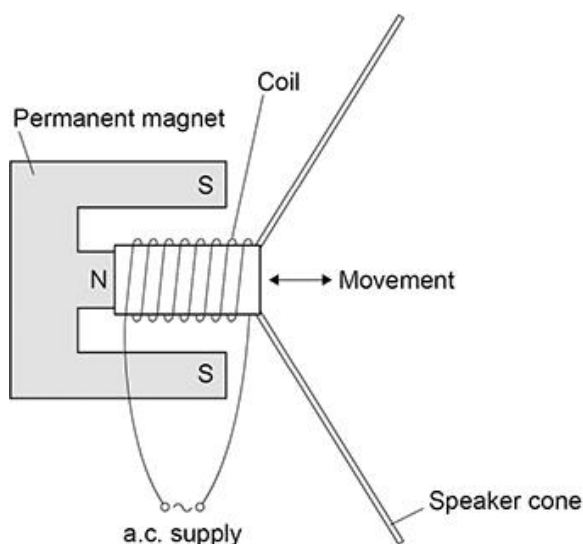

- (a) What is the name of the effect used by the moving-coil loudspeaker to produce sound waves?

\_\_\_\_\_

(1)



**Q13.** Figure 1 shows the construction of a simple transformer.

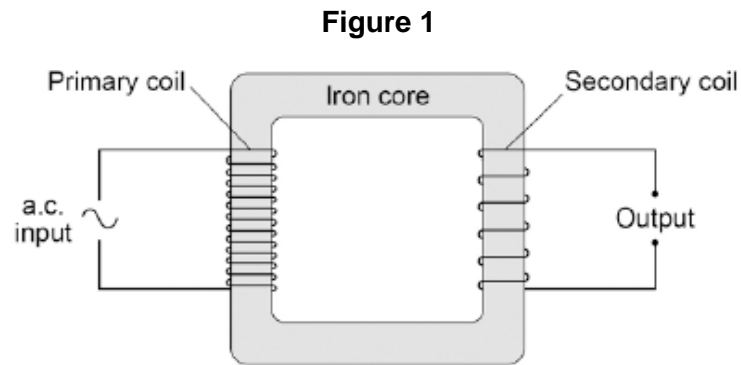

(a) Why is iron a suitable material for the core of a transformer?

Tick **one** box.

It is a metal.

It will not get hot.

It is easily magnetised.

It is an electrical conductor.

(1)

(b) A student makes three simple transformers, **J**, **K** and **L**.

**Figure 2** shows how the potential difference across the secondary coil of each transformer varies as the potential difference across the primary coil of each transformer is changed.

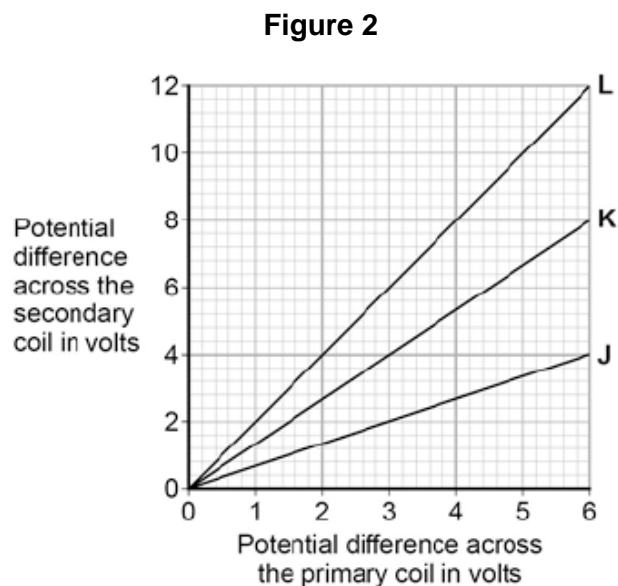

How can you tell that transformer **J** is a step-down transformer?

---

---

(1)

- (c) Each of the transformers has 50 turns on the primary coil.

Calculate the number of turns on the secondary coil of transformer **L**.

Use the correct equation from the Physics Equations Sheet.

---

---

---

Number of turns on the secondary coil = \_\_\_\_\_

(3)

(Total 5 marks)

**Q14.**

- (a) Complete the sentences.

The Sun is a stable star. This is because the forces pulling inwards caused by \_\_\_\_\_ are in equilibrium with the forces pushing outwards caused by the energy released by nuclear \_\_\_\_\_.

(2)

- (b) Write down the equation that links distance travelled ( $s$ ), speed ( $v$ ) and time ( $t$ ).

---

(1)

- (c) The mean distance between the Sun and the Earth is  $1.5 \times 10^{11}$  m.

Light travels at a speed of  $3.0 \times 10^8$  m/s.

Calculate the time taken for light from the Sun to reach the Earth.

---

---

---

---

---

Time = \_\_\_\_\_ s

(3)





**Q15.** Most galaxies are moving away from the Earth. Scientists can determine the speed of a galaxy by observing the light from the galaxy.

- (a) Complete the sentence. Choose the answer from the box.

<b>frequency</b>	<b>speed</b>	<b>wavelength</b>
------------------	--------------	-------------------

When scientists observe the light from distant galaxies, they observe an increase in the \_\_\_\_\_ of light from those galaxies.

(1)

The light spectra from stars and galaxies include dark lines. The lines have the same pattern. **Figure 1** shows the light spectrum from the Sun and from four galaxies.

**Figure 1**

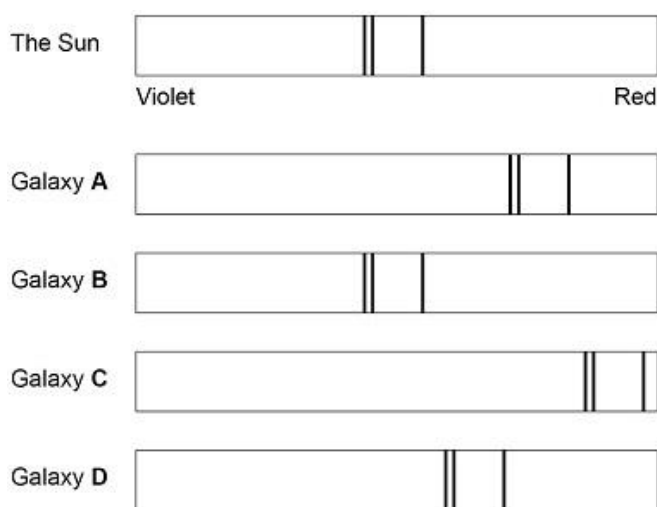

- (b) Which galaxy is moving the fastest away from the Earth?

Tick (✓) **one** box.

A       B       C       D

(1)

- (c) Which galaxy is the furthest away from the Earth?

Tick (✓) **one** box.

A       B       C       D

(1)

- (d) The Big Bang theory is one way to explain the origin of the universe. How does the Big Bang theory describe the universe when it began?

Tick (✓) **one** box.

Very big and very dense

Very dense and extremely hot

Very big and extremely hot

Very small and extremely cold

(1)

(e) Which statement about the Big Bang theory is correct?

Tick (✓) **one** box.

Scientists have proved that the theory is correct.

Scientific evidence supports the theory.

There is no other way to explain the origin of the universe.

(1)

(f) **Figure 2** shows three ways that the size of the universe may have changed with time.

**Figure 2**

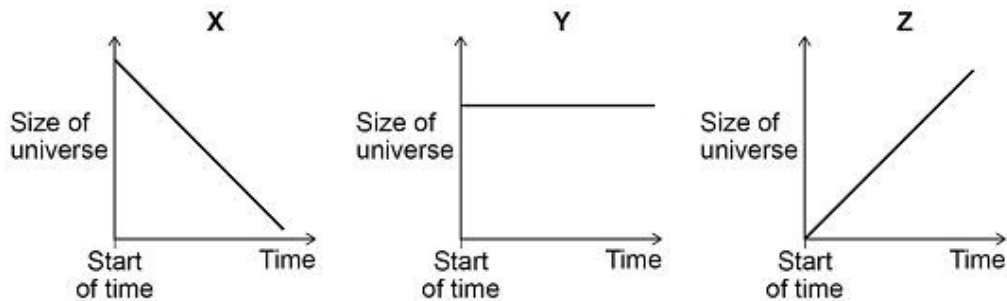

Which graph would the Big Bang theory suggest is correct?

Tick (✓) **one** box.

X       Y       Z

Give a reason for your answer.

---

---

(2)

(Total 7 marks)