

Algebraic Fluency

Rationale

Students of mathematics need to be fluent with algebraic manipulation to be able to use it as a tool to solve harder problems. This sheet is separated into two sections both of which have a focus on algebraic fluency.

Section A contains 15 multiple choice questions designed to highlight common student misconceptions when manipulating algebraic structures. Section B is a written section containing fairly standard, grade 7+ GCSE questions that focus on the key algebraic skills that every A level Maths and Further Maths student should be comfortable with when starting with us in September.

What you need to do

We suggest that you do all of the questions in section A and check your answers carefully.

We suggest that you use section B to refresh your maths knowledge on core GCSE principles. You may do all of these questions or some of them, depending on what you think is useful. Either way we expect you to arrive confident in the types of GCSE algebraic skills covered in these questions.

Section A: Algebraic Misconceptions Multiple Choice Exercise

Decide which of the multiple-choice answers are correct. Several questions may have several choices that are correct.

Q1. What is the value of $n^2 - n$ when $n = 2x$?

a) $4x^2 - 2x$

b) $2x^2 - 2x$

c) $2x$

d) $2x^2$

Q2. Which of these is the same as $(x - 3)^2$?

a) $x^2 - 6x + 9$

b) $x^2 - 6x - 9$

c) $x^2 - 9$

d) $x^2 + 9$

Q3. Which of these is the same as $a \times \frac{b}{c}$?

a) $\frac{ab}{ac}$

b) $\frac{ab}{c}$

c) $\frac{b}{ac}$

d) $\frac{b}{c} \div \frac{1}{a}$

Q4. Which of these is the same as $\frac{d}{b} \times \frac{b}{c} \times \frac{c}{e}$?

a) $\frac{d}{e}$

b) $\frac{d+b+c}{bce}$

c) $\frac{dbc}{bce}$

d) $\frac{dbc}{b+c+e}$

Q5. Which of these is equivalent to $a\sqrt{a}$?

a) $a^{3/2}$

c) $\sqrt{a^2}$

e) $\sqrt[3]{a^2}$

b) $\sqrt[3]{a}$

d) $\sqrt{a^3}$

f) $(\sqrt{a})^3$

Q6. Which of these is the same as $\frac{2x+y}{x}$?

a) $\frac{x+y}{x}$

b) $\frac{2+y}{x}$

c) $2 + y$

d) $\frac{4x+2y}{2x}$

e) $2 + \frac{y}{x}$

Q7. Which of these is the same as $1 \div (b \div c)$?

a) $\frac{b}{c}$

b) $\frac{c}{b}$

c) bc

d) cb

Q8. Which of these are the same as $\frac{1}{a} + \frac{1}{b} + \frac{1}{c}$?

a) $\frac{3}{a+b+c}$

b) $\frac{abc}{a+b+c}$

c) $\frac{ab+ac+bc}{abc}$

d) $\frac{a+b+c}{abc}$

Q9. If $A = 4 - 2x$ and $B = 6x - 3$, what is $A - B$?

a) $7 - 8x$

b) $1 - 4x$

c) $7 - 4x$

d) $1 - 8x$

Q10. What is $\frac{a}{b} \div b$?

a) $\frac{a}{b^2}$

b) $\frac{a}{b}$

c) a

d) $\frac{ba}{b}$

Q11. What is $\frac{1}{\sqrt{c}}$?

a) c

b) \sqrt{c}

c) $\frac{c}{\sqrt{c}}$

d) $\frac{\sqrt{c}}{c}$

Q12. There are lots of ways to rearrange the formula $A = c - \pi r^2$ to make r the subject.

Below are some different attempts – which are correct?

A

$$\begin{aligned} A &= c - \pi r^2 \\ A - c &= -\pi r^2 \\ c - A &= \pi r^2 \\ \pm\sqrt{c - A} &= \pi r \\ \frac{\pm\sqrt{c - A}}{\pi} &= r \end{aligned}$$

B

$$\begin{aligned} A + \pi r^2 &= c \\ \pi r^2 &= c - A \\ r^2 &= \frac{c - A}{\pi} \\ r &= \pm\sqrt{\frac{c - A}{\pi}} \end{aligned}$$

C

$$\begin{aligned} A &= c - \pi r^2 \\ A - c &= \pi r^2 \\ \frac{A - c}{\pi} &= r^2 \\ \pm\sqrt{\frac{A - c}{\pi}} &= r \end{aligned}$$

D

$$\begin{aligned} A &= c - \pi r^2 \\ A - c &= -\pi r^2 \\ \frac{A - c}{-\pi} &= r^2 \\ \pm\sqrt{\frac{A - c}{-\pi}} &= r \end{aligned}$$

E

$$\begin{aligned} A &= c - \pi r^2 \\ A - c &= -\pi r^2 \\ \frac{c - A}{\pi} &= r^2 \\ \pm\sqrt{\frac{c - A}{\pi}} &= r \end{aligned}$$

Q13. What is the solution to $x^2 + 2x - 15 \geq 0$?

a) $x \geq 3$

c) $-5 \leq x \leq 3$

b) $x \geq 3$ or $x \geq -5$

d) $x \leq -5$ or $x \geq 3$

Q14. If $x(a - b) - b(a - x) = 0$, then x must equal b ?

a) True

b) False

Note: Expanding

$$ax - bx - ab + bx = 0$$

$$ax - ab = 0$$

$$a(x - b) = 0$$

$$\text{So } a = 0 \text{ or } x = b$$

Q15. What is $(x \div (y \div z)) \div ((x \div y) \div z)$?

a) 1

b) $1 \div xyz$

c) x^2

d) y^2

e) z^2

Section B: Written Answers

Do as many or as few of the questions as you need to, but make certain that you are confident with the methods covered in these questions ahead of beginning the course in September. The questions focus on the following skills: surds, indices, manipulating algebraic expressions, factorising, expanding, arithmetic with algebraic fractions, completing the square, solving linear and quadratic equations/inequalities, understanding the relationship between equations and their graphs, and proof. Enjoy!

Indices and Surds - THIS IS A NON-CALCULATOR SECTION

1) Evaluate: $\frac{1}{27^{-\frac{2}{3}}}$

2) Write $(\sqrt[4]{8})^5$ as a power of 2.

3) Here is a sequence: 3 $3\sqrt{5}$ 15 $15\sqrt{5}$

Find the value of the 40th term.

4) Simplify $\sqrt{12} + \sqrt{75}$.

5) Simplify $\frac{4+2\sqrt{5}}{\sqrt{5}-1}$.

6) Show that $20\cos 30^\circ + 4\sin 60^\circ - 2\tan 60^\circ$ can be written in the form \sqrt{k} where k is an integer.

7) Work out the size of angle 'y':

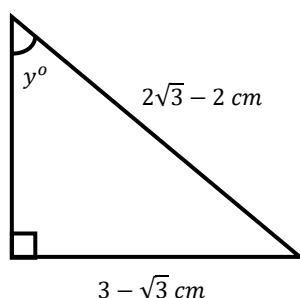

Algebraic Manipulation and equations

8) Expand and simplify: $(2x - 1)(x + 5)(3x - 2)$

9) Solve: $\frac{x}{x+6} = 5$

10) Solve this equation algebraically. $3x^2 + 8x - 5 = 0$
Give your solutions correct to 2 decimal places.

11) Solve by factorisation: a) $2x^2 - 19x - 33 = 0$

17. b) $5x^2 + 7x + 2 = 0$

12) Solve the inequality: $x^2 - 5x - 6 \leq 0$

13) Write as a single fraction in its simplest form: $\frac{x}{x+2} + \frac{x+1}{x-2} - \frac{6x}{x^2-4}$

14) Solve this equation, giving your answers correct to 1 decimal place:

$$\frac{5}{x+2} + \frac{3}{x-3} = 2$$

15) Show that $\frac{2x^2+13x+20}{2x^2+x-10}$ simplifies to $\frac{x+a}{x-b}$ where a and b are integers.

16) Solve: $x^2 + y^2 = 34$

$$y - x = 2$$

17) The base of a cone is fixed to the top of a cylinder to make a decoration.

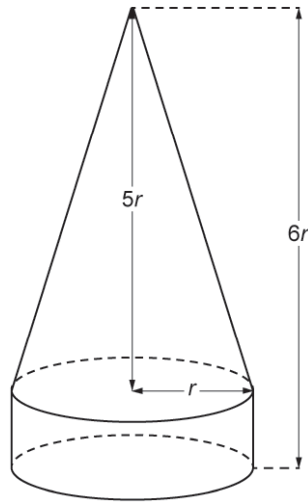

The radius of the base of the cone and of the cylinder is r cm.
The cone's height is $5r$ cm.

The total height of the decoration is $6r$ cm.
The total volume of the decoration is 225 cm^3 .

Calculate the value of r .

Show your working.

18) In the diagram, the square and the trapezium share a common side of length x cm.

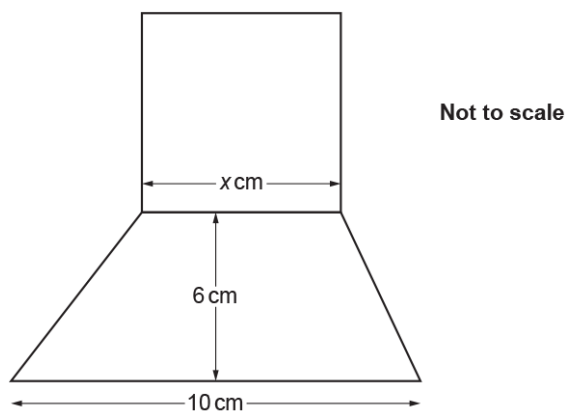

The area of the square is equal to the area of the trapezium.

Work out the value of x .

Graphs and Coordinate Geometry

19) P is the point $(0, -1)$ and Q is the point $(5, 9)$.

Find the equation of the line through P that is perpendicular to the line PQ.

20) (a) Write $x^2 - 10x + 22$ in the form $(x - a)^2 - b$.

(b) Sketch the graph of $y = x^2 - 10x + 22$.

Show clearly the coordinates of any turning points and the value of the y-intercept.

21) The graph of $y = 2x^2 + 3x - 9$ is drawn below.

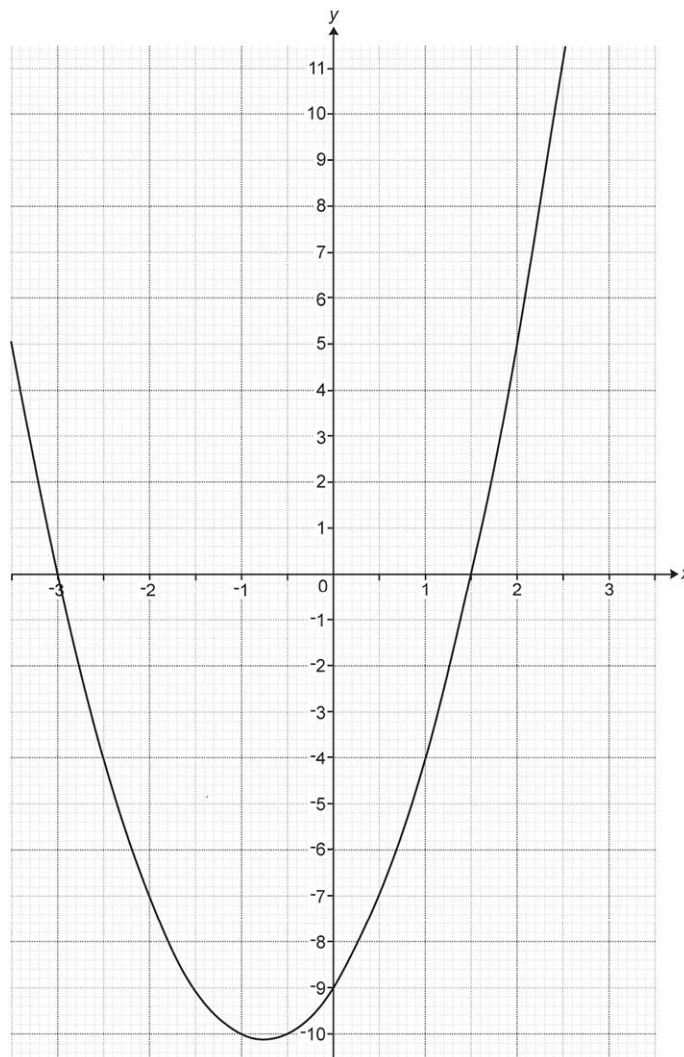

The equation $2x^2 + x - 4 = 0$ can be solved by finding the intersection of the graph of $y = 2x^2 + 3x - 9$ and the line $y = ax + b$.

i. Find the value of a and the value of b .

ii. Hence **use the graph** to solve the equation $2x^2 + x - 4 = 0$.

22) The diagram shows a circle with centre $(0, 0)$ and a tangent at the point $(-12, 16)$.

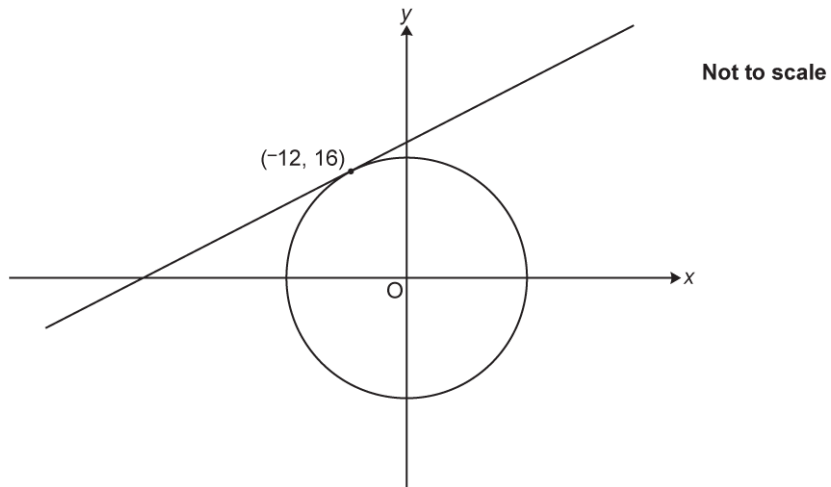

The tangent crosses the y -axis at the point $(0, p)$. Find the value of p .

23) The graph of $y = x^3 - x^2 - 2$ is drawn on the grid.

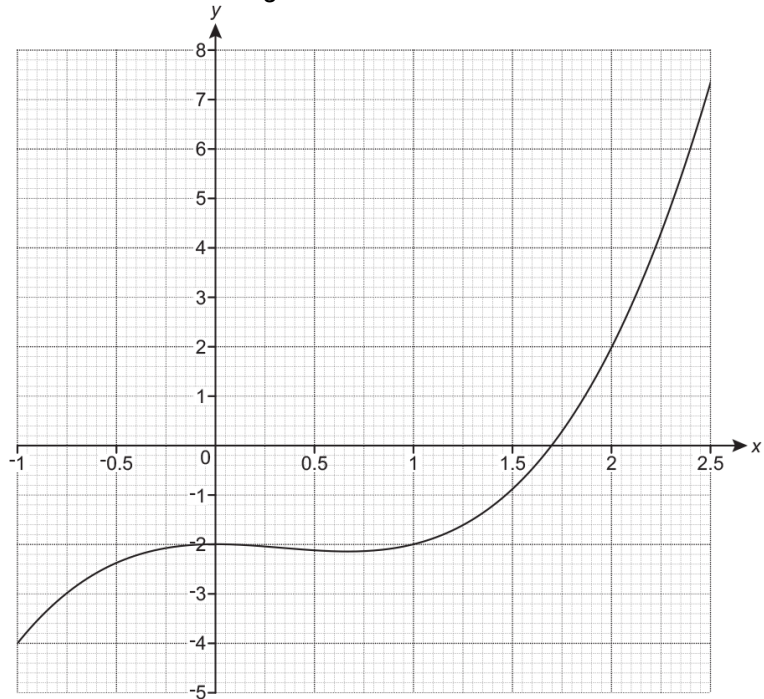

Use the graph to solve $x^3 - x^2 - 2 = 0$.
Give your answer correct to 1 decimal place.

24) The sketch shows part of a graph which has equation $y = ax^2 + bx + c$.

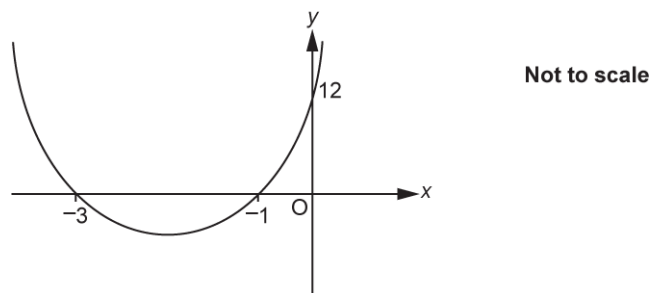

Find the values of a , b and c .

Proof

25) Bethany says that $(2x)^2$ is always greater than or equal to $2x$.

Decide whether she is correct or not.
Show your working to justify your decision.

26) Nine consecutive numbers are written on a 3-by-3 grid.
They are arranged, in ascending order, in a spiral as shown.

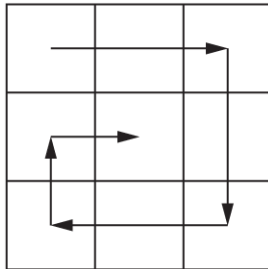

Victor says:

"If **any** nine consecutive numbers are arranged in ascending order in this spiral on a 3-by-3 grid, the total of the first column will **always** be one less than the total of the second column."

Prove that Victor is correct.

27) OAB is a sector of a circle, centre O .
 $OA = 6$ cm and AX is perpendicular to OB .

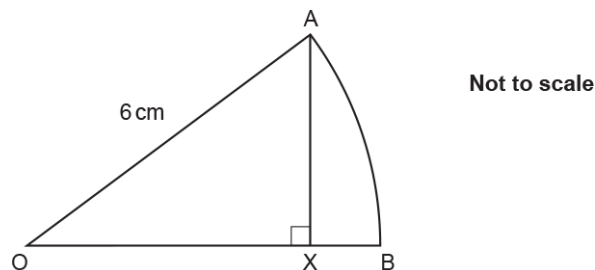

The area of sector OAB is $6\pi\text{cm}^2$. Show that $AX = 3\sqrt{3}$

28) This question is about a row of congruent circles inscribed inside a larger circle so that the circles all lie on the diameter of the larger circle. The diagram below shows the case with three circles.

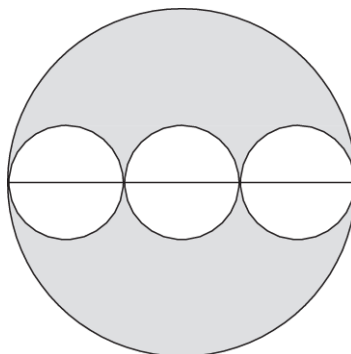

a) Find the fraction of the large circle that is shaded in the diagram shown

- b) Suppose we had drawn 4 or 5 circles along the diameter, what fraction of the circle would have been shaded?
Hypothesise a general result for 'n' circles and prove it.

Answers

Indices and Surds - THIS IS A NON-CALCULATOR SECTION

- 1) 18
 2) $2^{\frac{15}{4}}$
 3) $57,220,458,984,375\sqrt{5}$
 4) $7\sqrt{3}$
 5) $\frac{3\sqrt{5} + 7}{2}$
 6) $10\sqrt{3}$
 7) 60°

Algebraic Manipulation and equations

- 8) $6x^3 + 23x^2 - 33x + 10$
 9) $-7\frac{1}{2}$
 10) -3.19 or $[0].52$
 11) a) $(2x + 3)(x - 11)$ so $x = -3/2$ or 11
 b) $(5x + 2)(x + 1)$ so $x = -5/2$ or -1
 12) $-1 \leq x \leq 6$
 13) $\frac{2x - 1}{x + 2}$
 14) -0.3 5.3
 15) $\frac{2(x+5)(x+4)}{2(x+5)(x-2)} = \frac{x+4}{x-2}$
 16) $x = -5$ and $y = -3$ or $x = 3$ and $y = 5$
 17) 2.99 [cm]
 18) 7.17 to 7.18 or 7.2

Graphs and Coordinate Geometry

- 19) $y = -\frac{1}{2}x - 1$
 20) a) $(x - 5)^2 - 3$
 b) Correct sketch with TP at $(5, -3)$ in 4th quadrant and y - intercept at $(0, 22)$
 21) $a = 2$ and $b = -5$
 22) 25

23) 1.7

24) 4, 16, 12

Proof

25) Proof could be by counter example eg $x = 0.01$

Or by looking to see when $(2x)^2 > 2x$ (when $x < 0$ or when $x > 1/2$)

26) First column:

$$n + (n + 7) + (n + 6) = 3n + 13$$

Second column:

$$(n + 1) + (n + 8) + (n + 5) = 3n + 14$$

Difference: $(3n + 14) - (3n + 13) = 1$

27) ----

28) a) $\frac{2}{3}$ b) $\frac{n-1}{n}$ where $n = \text{number of smaller circles}$